



**COMPLIANCE
ENGINEERING**
EMC Product Safety Environmental Shielding

90 Indian Drive
Keysborough VIC 3173 Australia
Telephone: + 61 3 9763 3079
Email: info@compeng.com.au
Web: www.compeng.com.au
ABN: 56 101 639 588

RF Shielded Box Model: CEMS5050

Internal: 481(W)*494(D)*481(H) mm
External: 515(W)*550(D)*515(H) mm
Weight: 20 kg
Shielding: 0.7 to 8 GHz (>70 dB)
Interfaces: Options include: USB, RJ45, DC, AC, SMA, BNC & RCA
(Up to 6 interface sections can be installed)

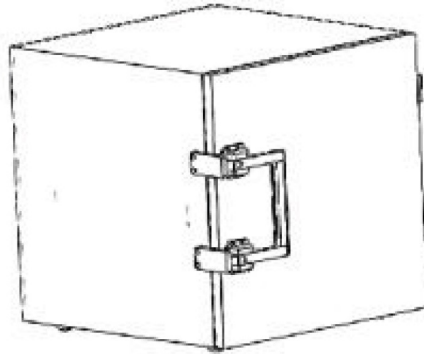

(Example of an interface section)





COMPLIANCE ENGINEERING

EMC Product Safety Environmental Shielding

90 Indian Drive
Keysborough VIC 3173 Australia
Telephone: + 61 3 9763 3079
Email: info@compeng.com.au
Web: www.compeng.com.au
ABN: 56 101 639 588

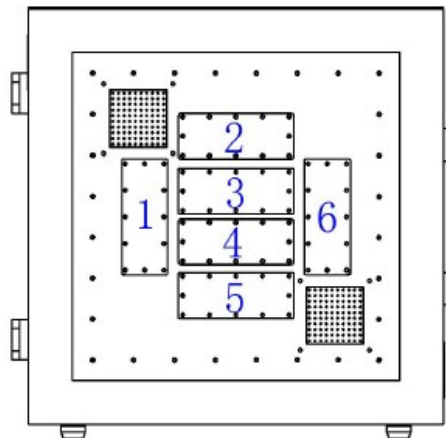
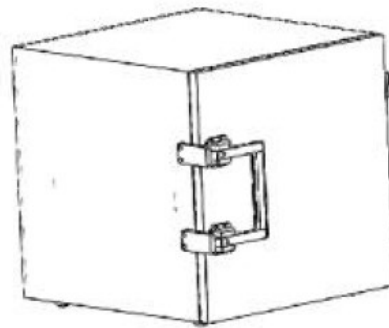
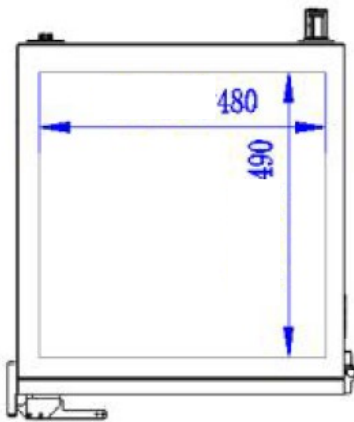
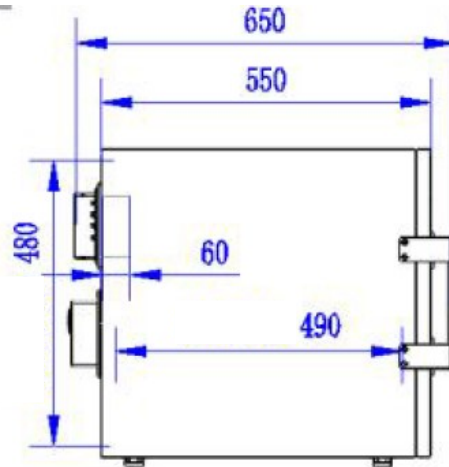
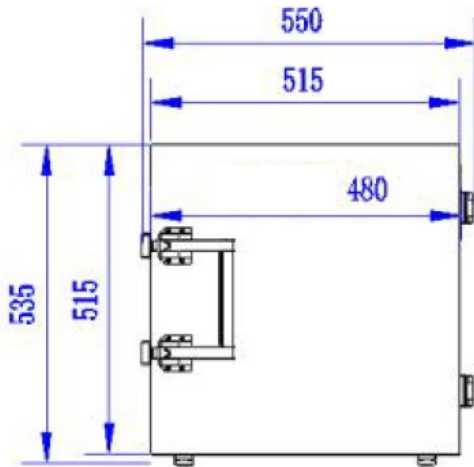

Rear