



**COMPLIANCE
ENGINEERING**
EMC Product Safety Environmental Shielding

90 Indian Drive
Keysborough VIC 3173 Australia
Telephone: + 61 3 9763 3079
Email: info@compeng.com.au
Web: www.compeng.com.au
ABN: 56 101 639 588

RF Shielded Box

Model: CEMS5040

Internal: 500(W)*400(D)*406(H) mm
External: 636(W)*524(D)*530(H) mm
Weight: 36 kg
Shielding: 0.9 to 5.8 GHz (>65 dB)
Interfaces: Options include: USB, RJ45, DC, AC, SMA, BNC & RCA
(Up to 4 interface sections can be installed)



(Example of an interface section)

DC*2+USB*2+RJ45*2





**COMPLIANCE
ENGINEERING**
EMC Product Safety Environmental Shielding

90 Indian Drive
Keysborough VIC 3173 Australia
Telephone: + 61 3 9763 3079
Email: info@compeng.com.au
Web: www.compeng.com.au
ABN: 56 101 639 588

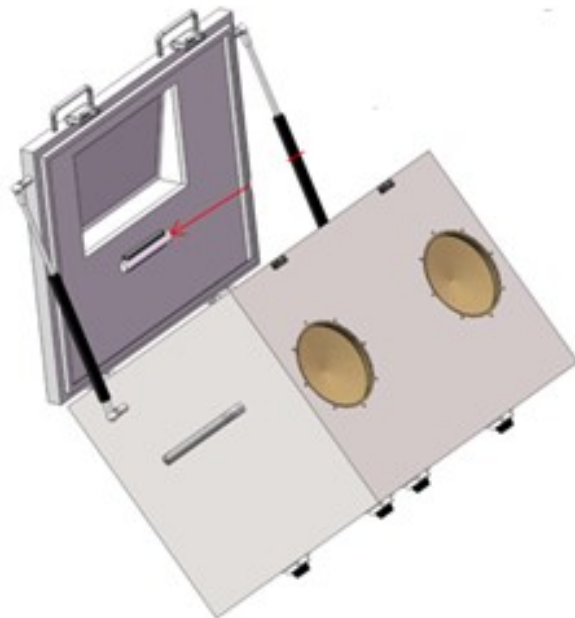
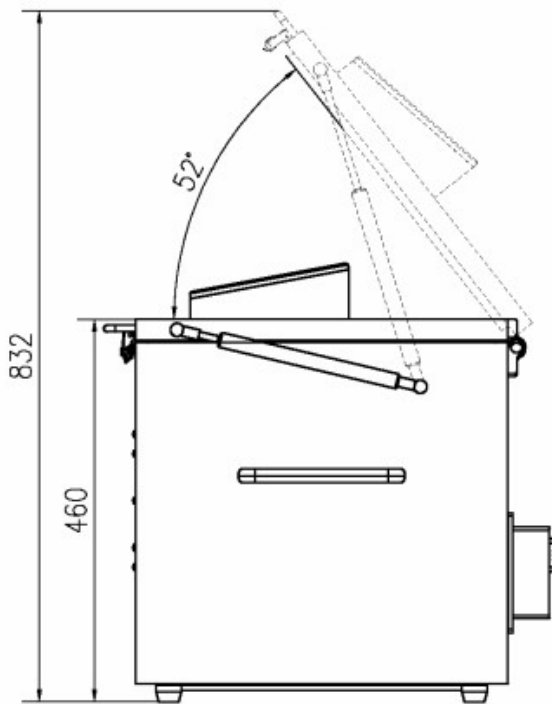
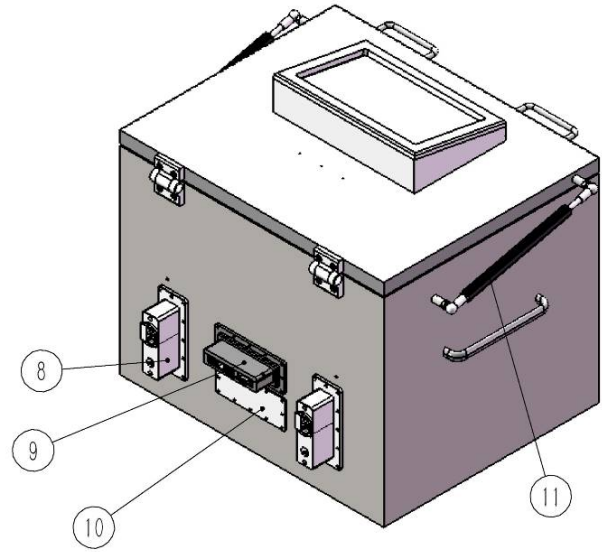
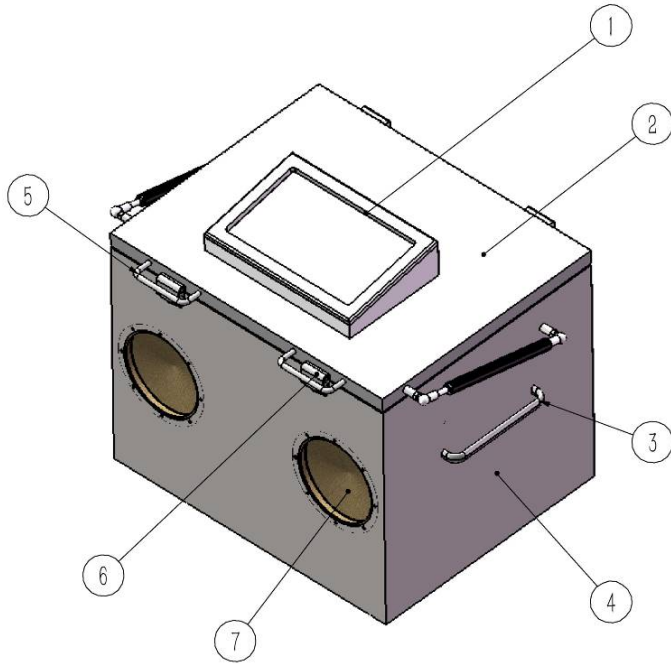



**COMPLIANCE
ENGINEERING**
EMC Product Safety Environmental Shielding

90 Indian Drive
Keysborough VIC 3173 Australia
Telephone: + 61 3 9763 3079
Email: info@compeng.com.au
Web: www.compeng.com.au
ABN: 56 101 639 588

