

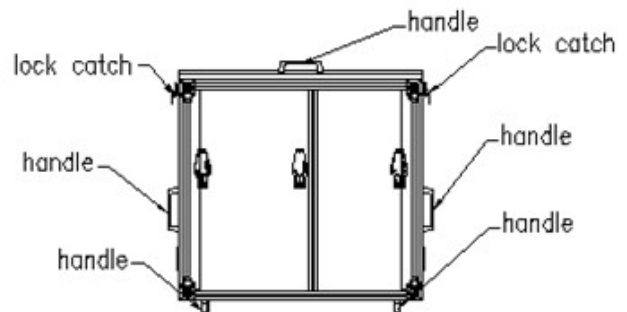

# RF Shielded Cabinet

## Model: CEMS110100

- Internal: 696(W)\*686(D)\*696(H) mm  
External: 858.5(W)\*856(D)\*696(H) mm  
Weight: 180 kg (approx.)  
Shielding: 0.8 to 3 GHz (>80 dB)  
Interfaces: Options include: USB, RJ45, DC, AC, SMA, BNC & RCA  
(Up to 2 interface sections + SMA can be installed)

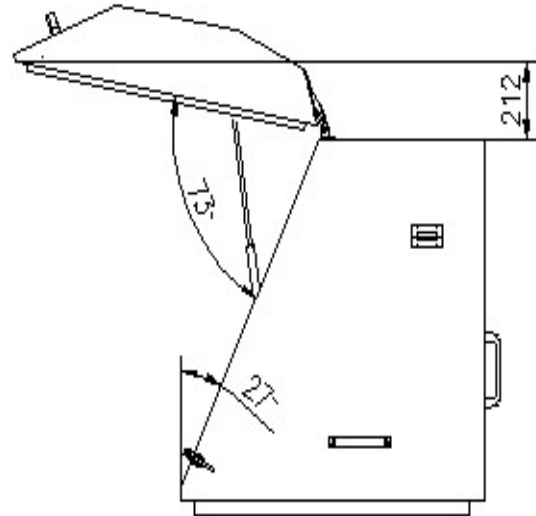
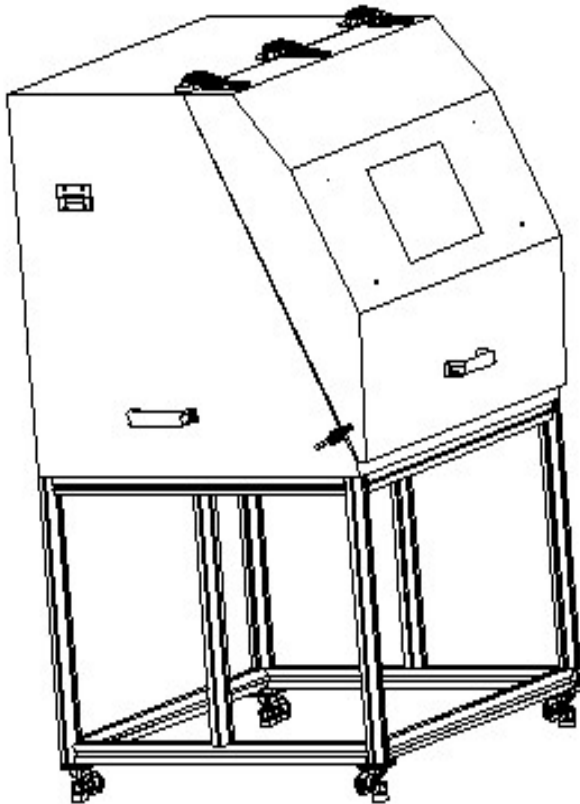

(Example of an interface section)





**COMPLIANCE  
ENGINEERING**  
EMC Product Safety Environmental Shielding

90 Indian Drive  
Keysborough VIC 3173 Australia  
Telephone: + 61 3 9763 3079  
Email: [info@compeng.com.au](mailto:info@compeng.com.au)  
Web: [www.compeng.com.au](http://www.compeng.com.au)  
ABN: 56 101 639 588

